

LOC	DIST	REVISIONS			
AA	22	REV	DATE	BY	CHK
		C	REV: EC 067A-0206-98	09FEB99	DJA DK

- 1 MATERIAL: HOUSING-HIGH TEMPERATURE THERMOPLASTIC, BLACK. TERMINALS-0.31(.012) THICK COPPER ALLOY PLATED WITH 1.27um(.000050) MINIMUM THICK GOLD IN LOCALIZED GOLD PLATE AREA, 2.5um(.000100) MINIMUM TIN-LEAD ON TERMINATION END, BOTH OVER 1.27um(.000050) MINIMUM NICKEL OVER ENTIRE TERMINAL.
- 2 JACK CAVITY CONFORMS TO FCC RULES AND REGULATIONS, PART 68 SUBPART F.
- 3 PACKAGING-MATERIAL: ANTI-STATIC, RIGID EXTRUDED, TRANSPARENT PLASTIC TUBE 558.82±1.27 [22.0±.05] LONG. 22 PIECES PER TUBE. SEE DETAIL D.

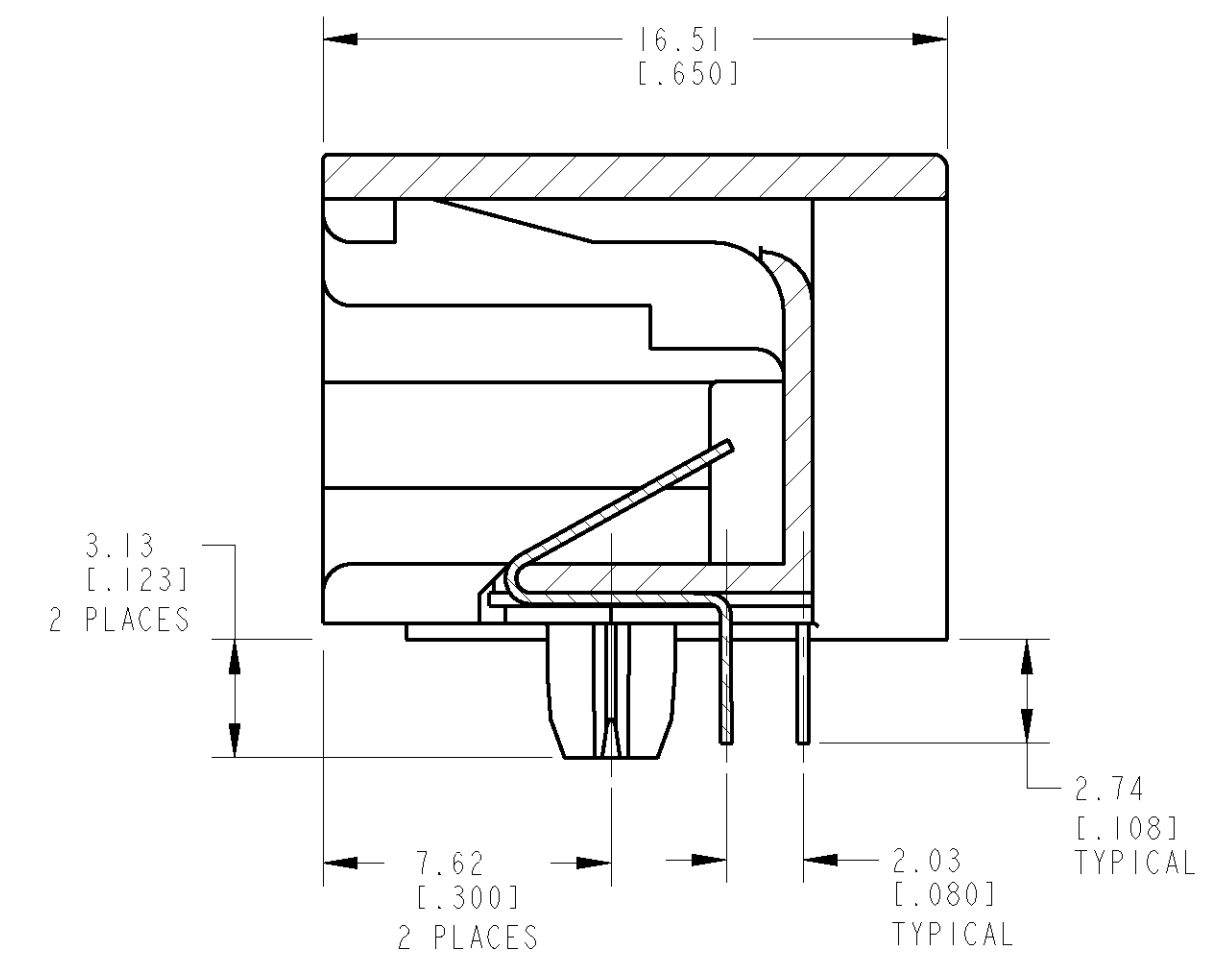

SECTION C-C

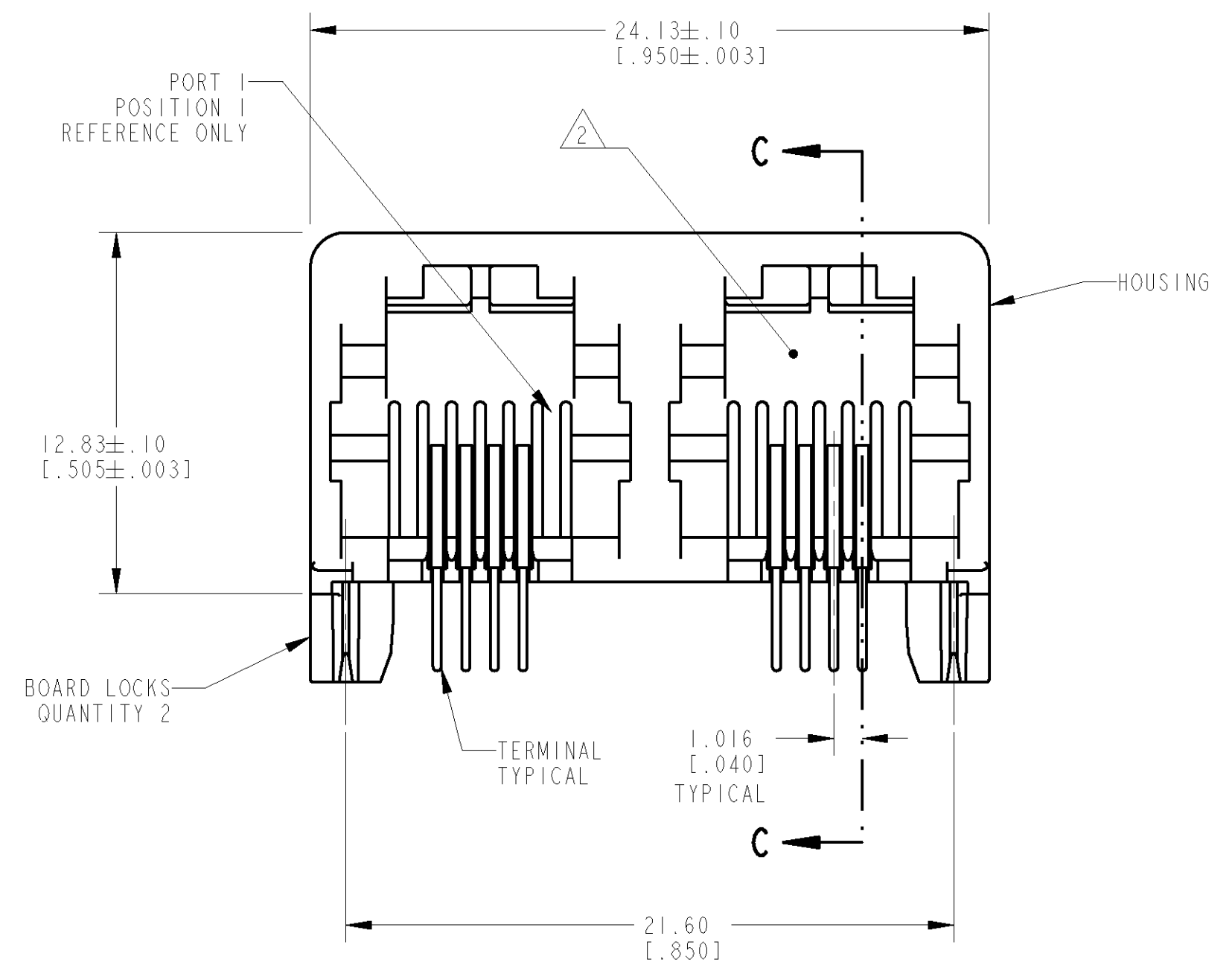
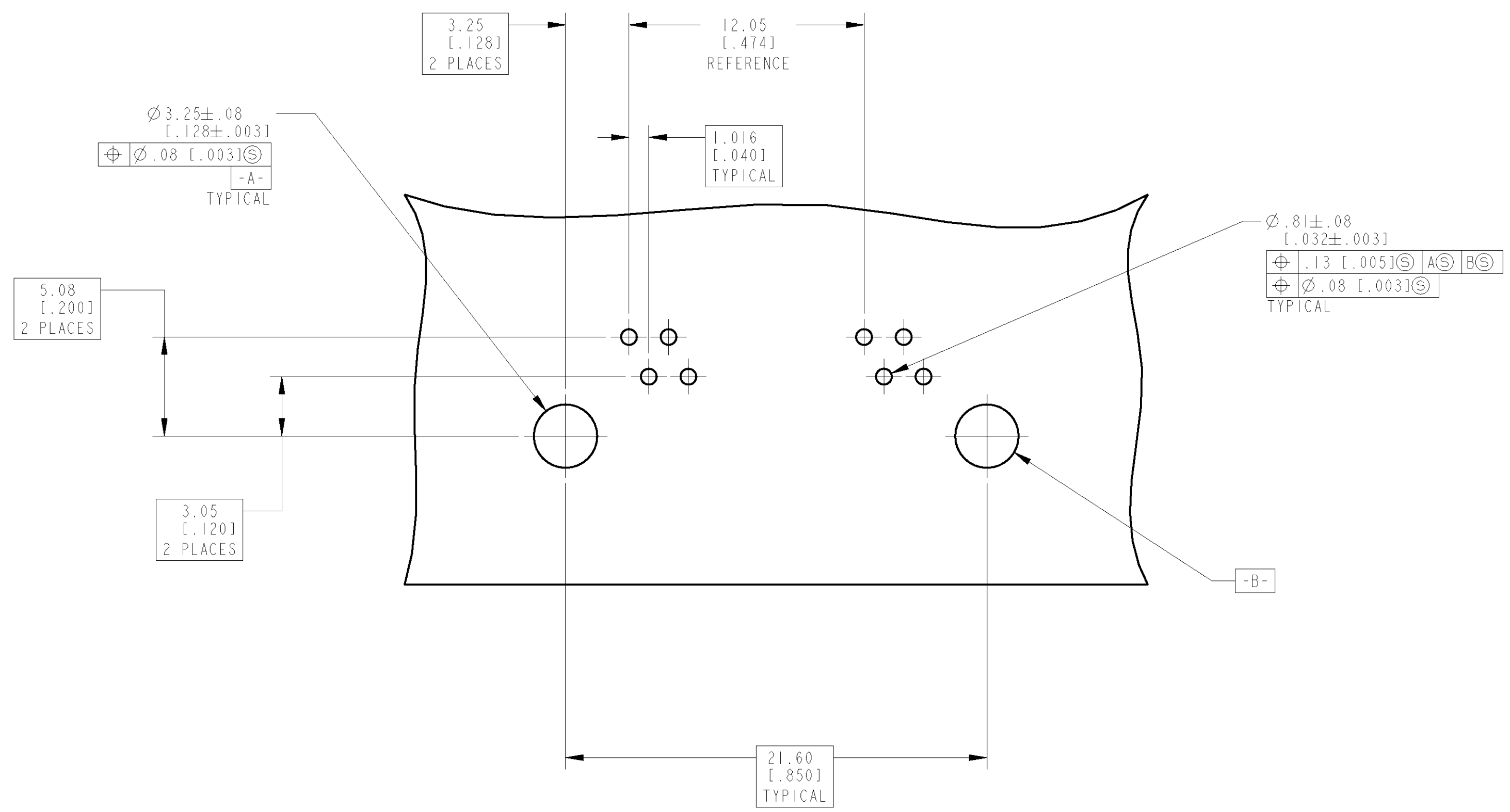
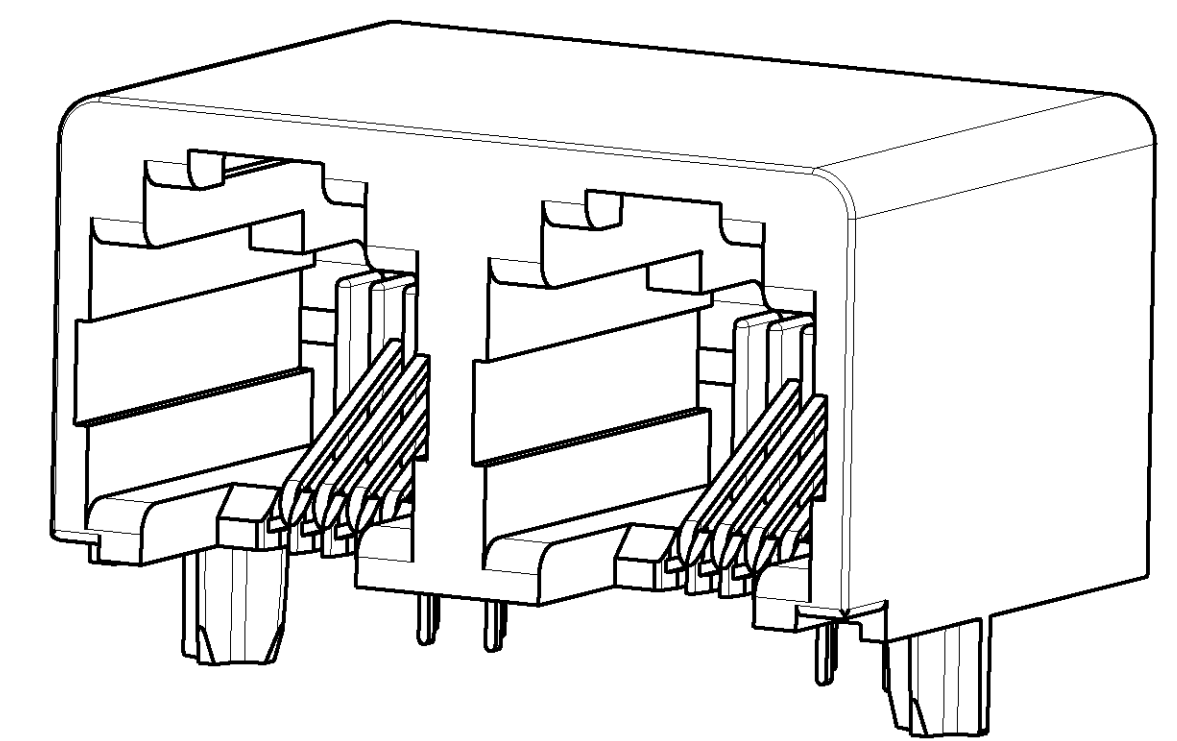

RECOMMENDED PRINTED CIRCUIT BOARD LAYOUT
 COMPONENT SIDE-VIEWED FROM TOP
 THICKNESS 1.57[.062]

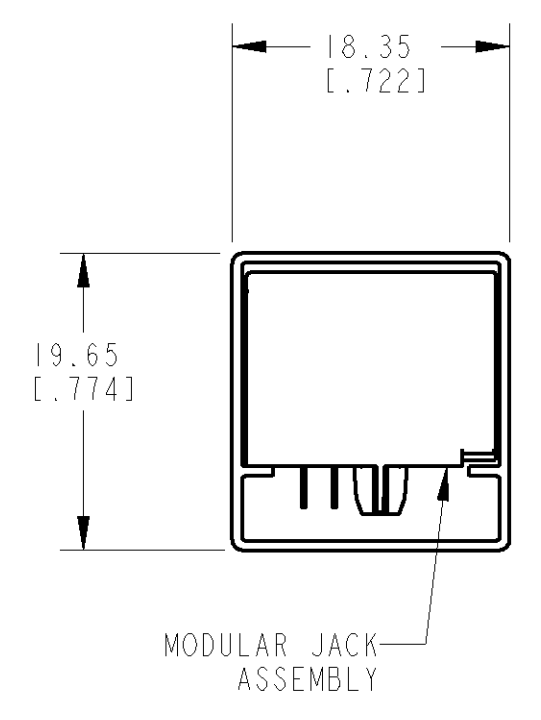
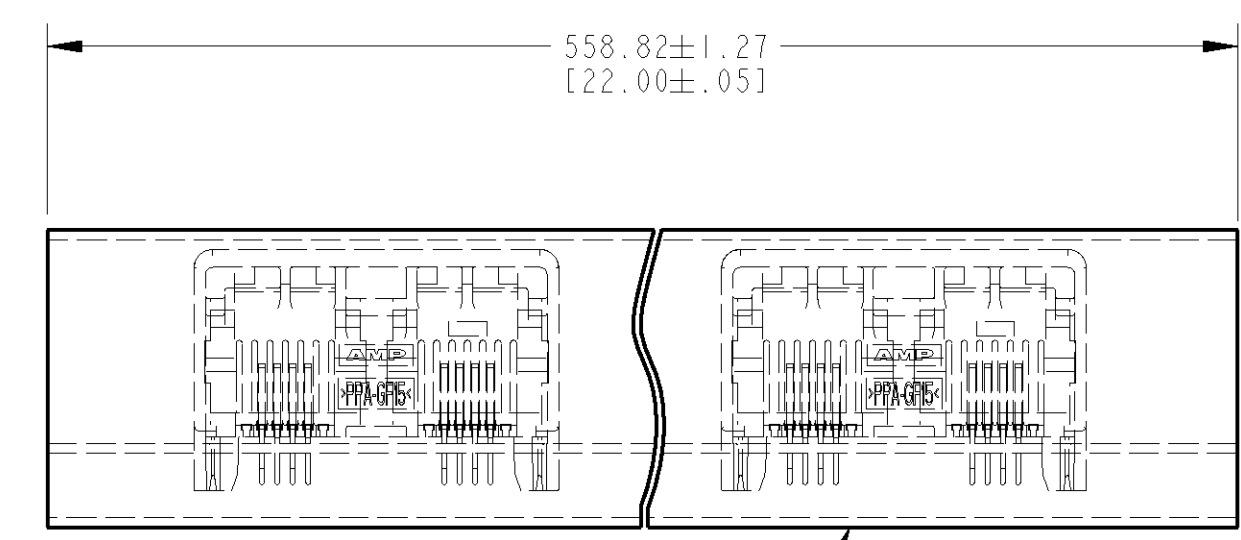

DETAIL D
 SCALE 2:1

PACKAGING	406904-1
PART NUMBER	

<small>THIS DRAWING IS A CONTROLLED DOCUMENT FOR AMP INCORPORATED. ALL CONTACTS ARE OWNED AND THE CONTROLLED DOCUMENTS ORGANIZATION SHOULD BE CONTACTED FOR THE LATEST REVISION.</small>		DWN D STRAUSSER 16APR98 CHK D KEMPKA 06MAY98 APD D KEMPKA 06MAY98	AMP Incorporated Harrisburg, PA 17105-3608
DIMENSIONS: mm [INCHES]	TOLERANCES UNLESS OTHERWISE SPECIFIED: 0 PLC ± 1 PLC ± 2 PLC ±0.13(.005) 3 PLC ± 4 PLC ± ANGLES ±	PRODUCT SPEC 108-1689 APPLICATION SPEC 114-2048 WEIGHT 2.54 gr/ams CUSTOMER DRAWING	NAME MODULAR JACK ASSEMBLY 2 PORT, 6/4, RIGHT ANGLE THRU HOLE, RJ-11 SIZE CAGE CODE DRAWING NO. 00779 C=406904 RESTRICTED TO
MATERIAL	FINISH	SCALE 5:1	SHEET 1 OF 1 REV C